

Collegamenti elettrici / Wiring

ON-OFF + EMERGENZA (cod. 2689/EM, 2690/EM)

I neutri possono essere messi in comune.
Neutrals can be pooled.

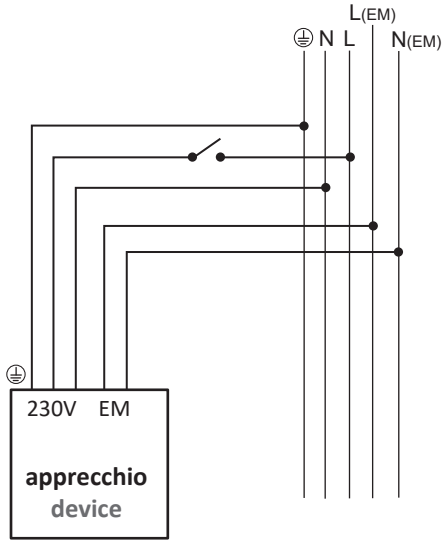

ON-OFF doppia accensione (cod. 2693) ON-OFF double switch

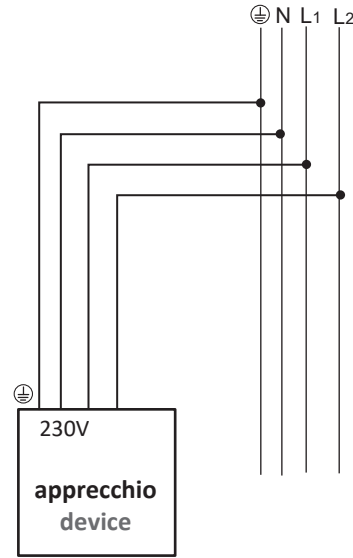

30W DALI + 20W ON-OFF (cod. 2693/D2)

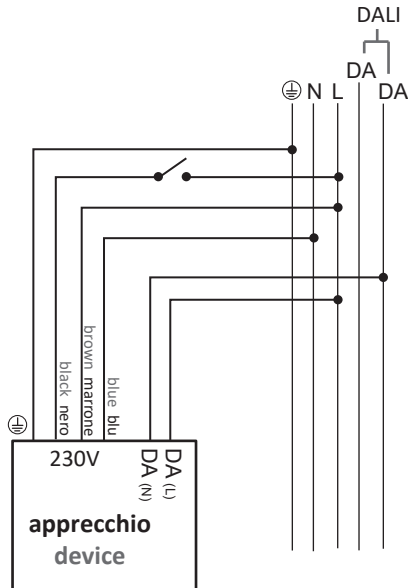

30W SWITCH-DIM + 20W ON-OFF (cod. 2693/D3)

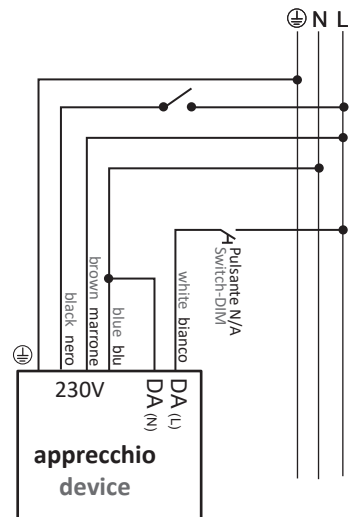

Ring

plafone / ceiling

ISTRUZIONI PER L'INSTALLAZIONE
INSTRUCTIONS FOR INSTALLING
MODE D'INSTALLATION
MONTAGEANWEISUNGEN
INSTRUCTIES VOOR HET INSTALLEREN
INSTRUCCIONES PARA INSTALACION

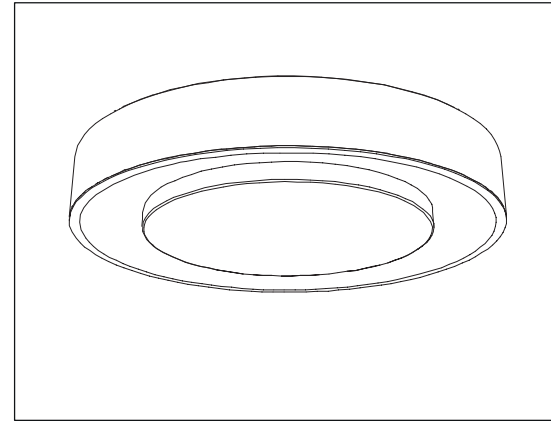

ATTENZIONE:

La sicurezza dell'apparecchio è garantita solo dall'uso appropriato delle seguenti istruzioni, pertanto è necessario rispettarle e conservarle.

WARNING:

Device security is guaranteed by the appropriate use of the following directions, therefore it is required to follow and to keep them.

ATTENTION:

La sécurité de l'appareil n'est garantie que dans le respect des instructions suivantes, nous vous conseillons donc de les bien conserver.

ACHTUNG:

Die Gerätesicherheit ist versichert unter der Voraussetzung, daß die folgenden Einleitungen richtig verwendet und eingehalten werden. Deshalb ist es notwendig, sie zu bewahren.

ATTENTIE:

De veiligheid van het armatuur is alleen gegarandeerd bij het juist toepassen van de volgende montage-voorschriften.

ATENCIÓN:

La seguridad del aparato se garantiza solo cumpliendo cuidadosamente las siguientes instrucciones; por ello, es necesario conservarlas.



I Apparecchio predisposto per il montaggio diretto su superfici normalmente infiammabili.

I Apparecchio di classe I

I Gruppo di rischio 0, secondo norma EN 62471:2008

GB Device fitted for directly mounting onto normally inflammable surfaces.

GB Class I luminaire

GB Risk group 0, in compliance with standard EN 62471:2008

F Appareil réalisé pour le montage direct sur surfaces normalement inflammables.

F Appareil de classe I

F Groupe de risque 0, suivant la norme EN 62471:2008

D Leuchte geeignet zur Montage auf normalerweise Flächen.

D Garret Klasse I

D Risikogruppe 0, gemäß Vorschrift EN 62471:2008

NL Toestellen voorzien voor montage op normaal brandbare oppervlakten.

NL Toestellen van Klasse I

NL Risicogroep 0, volgens de norm EN 62471:2008

E Aparato preparado para ser montado directamente en superficies inflamables.

E Aparato de clase I

E Grupo de riesgo 0, según norma EN 62471:2008

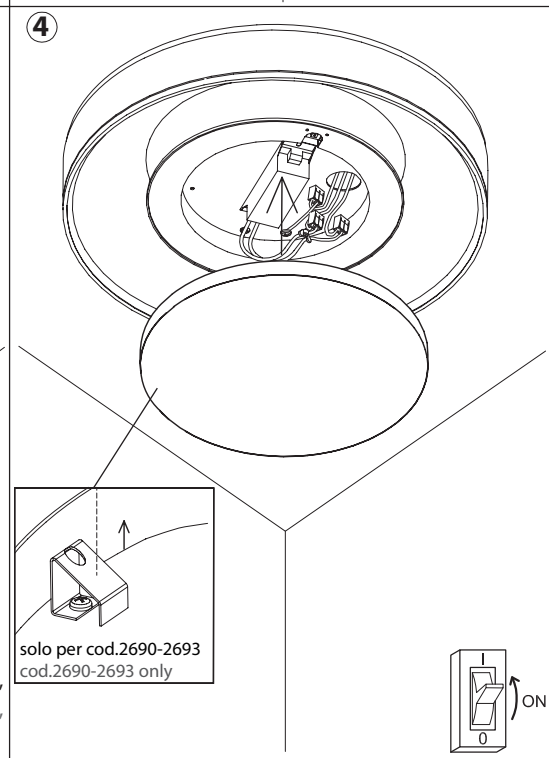
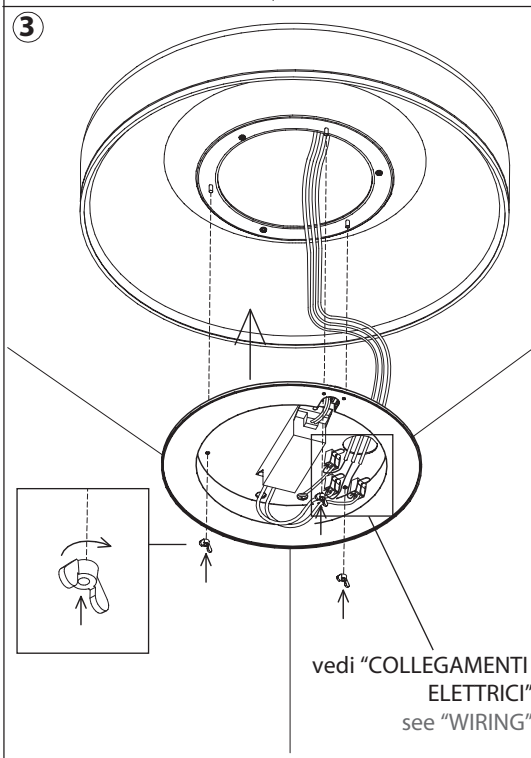
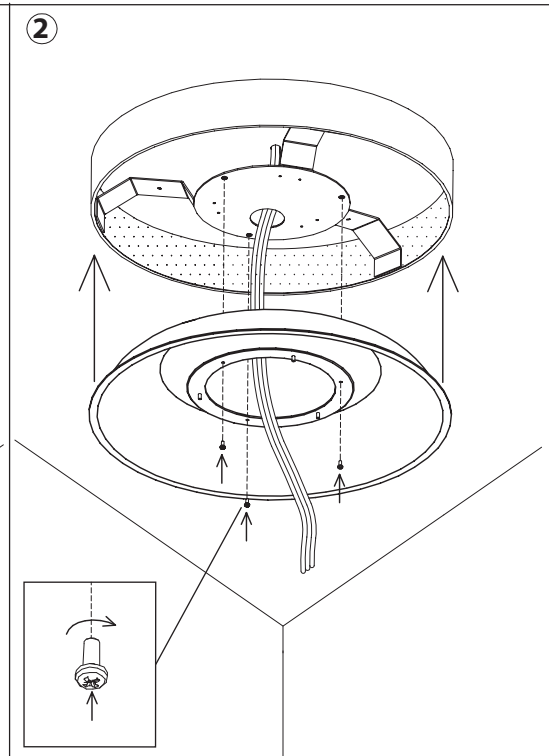
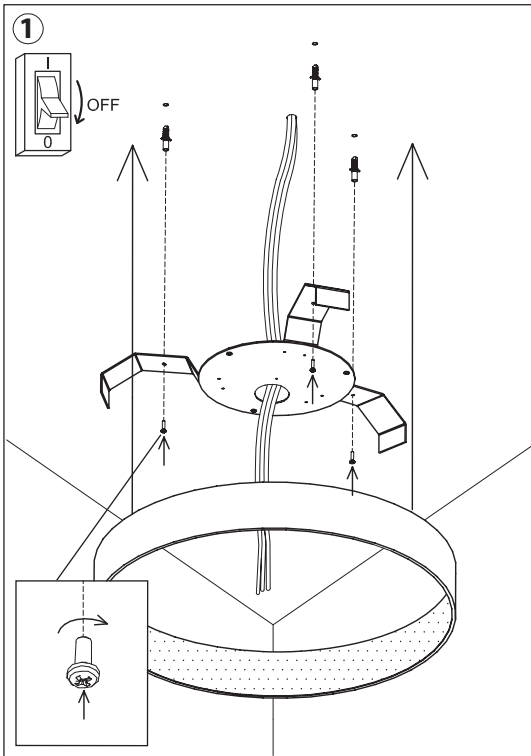

Collegamenti elettrici / Wiring

ON-OFF (cod.2689, 2690)

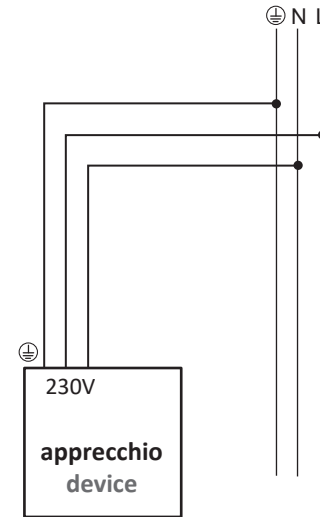

TAGLIO DI FASE (cod. 2689/DTF, 2690/DTF)
PHASE CUT DIMMER

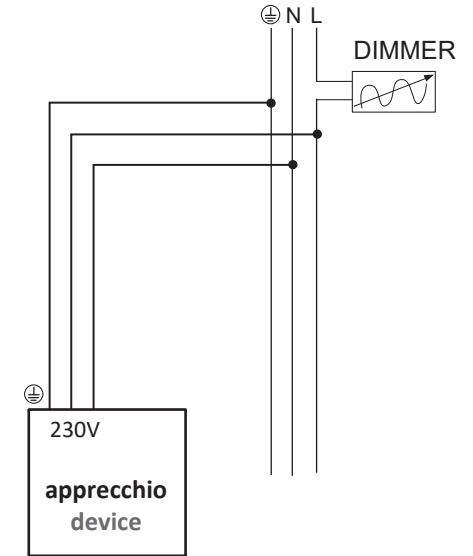

DALI (2689/D2, 2690/D2)

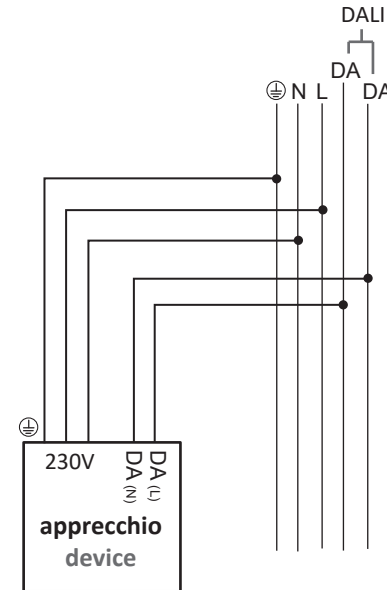

SWITCH-DIM (2689/D3, 2690/D3)

