

Teo quadro

incasso / recessed

ISTRUZIONI PER L'INSTALLAZIONE
INSTRUCTIONS FOR INSTALLING
MODE D'INSTALLATION
MONTAGEANWEISUNGEN
INSTRUCTIES VOOR HET INSTALLEREN
INSTRUCCIONES PARA INSTALACION

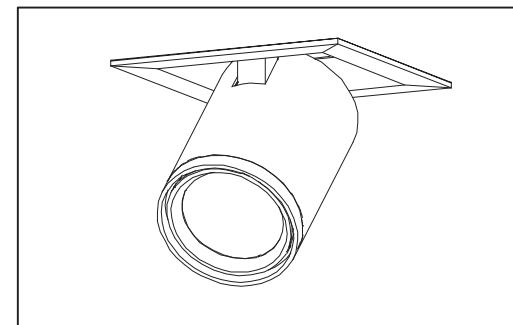

ATTENZIONE:

La sicurezza dell'apparecchio è garantita solo dall'uso appropriato delle seguenti istruzioni, pertanto è necessario rispettarle e conservarle.

WARNING:

Device security is guaranteed by the appropriate use of the following directions, therefore it is required to follow and to keep them.

ATTENTION:

La sécurité de l'appareil n'est garantie que dans le respect des instructions suivantes, Nous vous conseillons donc de les bien conserver.

ACHTUNG:

Die Gerätsicherheit ist versichert unter der Voraussetzung, daß die folgenden Einleitungen richtig verwendet und eingehalten werden. Deshalb ist es notwendig, sie zu bewahren

ATENCIÓN:

De veiligheid van het armatuur is alleen gegarandeerd bij het juist toepassen van de volgende montage-voorschriften.

ATENCIÓN:

La seguridad del aparato se garantiza solo cumpliendo cuidadosamente las siguientes instrucciones; por ello, es necesario conservarlas.



I Apparecchio predisposto per il montaggio diretto su superfici normalmente infiammabili.

GB Device fitted for directly mounting onto normally inflammable surfaces.

F Appareil réalisepour le montage direct sur superficies normalement inflammables.

D Leuchte geeignet zur Montage auf normalerweise Flächen.

NL Toestellen voorzien voor montage op normaal brandbare oppervlakten.

E Aparato preparado para ser montado directamente en superficies inflamables.

I Apparecchio di classe I

GB Class I luminaire

F Appareil de classe I

D Garael Klasse I

NL Toestellen van Klasse I

E Aparato de clase I



I Apparecchio di classe II

GB Class II luminaire

F Appareil de classe II

D Garael Klasse II

NL Toestellen van Klasse II

E Aparato de clase II

I Gruppo di rischio 1, secondo norma EN 62471:2008

GB Risk group 1, in compliance with standard EN 62471:2008

F Groupe de risque 1, suivant la norme EN 62471:2008

D Risikogruppe 1, gemäß Vorschrift EN 62471:2008

NL Risicogroep 1, volgens de norm EN 62471:2008

E Grupo de riesgo 1, según norma EN 62471:2008



I L'apparecchio non deve, in alcuna circostanza, essere coperto con materiale isolante.

GB The fixture must not be covered, under any circumstances, by insulating materials or like.

F L'appareil ne doit, en aucun cas, être couvert par un matériau isolant ou autre.

D Das Gerät darf auf keinen Fall mit Isoliermaterial oder ähnlichem bedeckt werden.

NL Het apparaat mag in geen geval bedekt worden met isoleringsmateriaal of dergelijke.

E El aparato no debe ser protegido con material aislante o parecido, por ninguna causa.

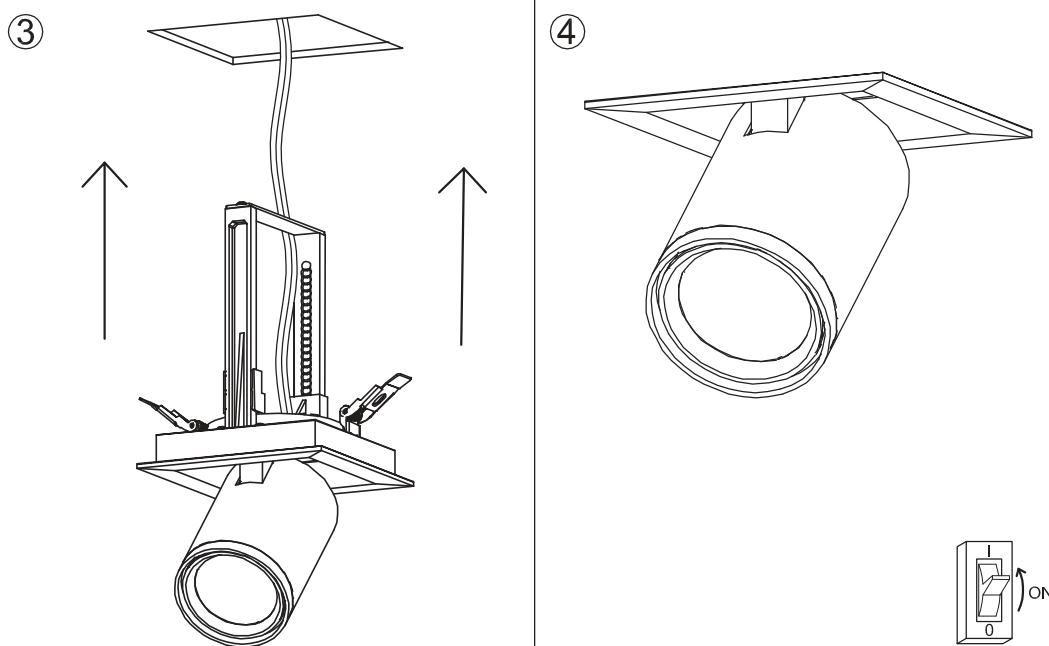
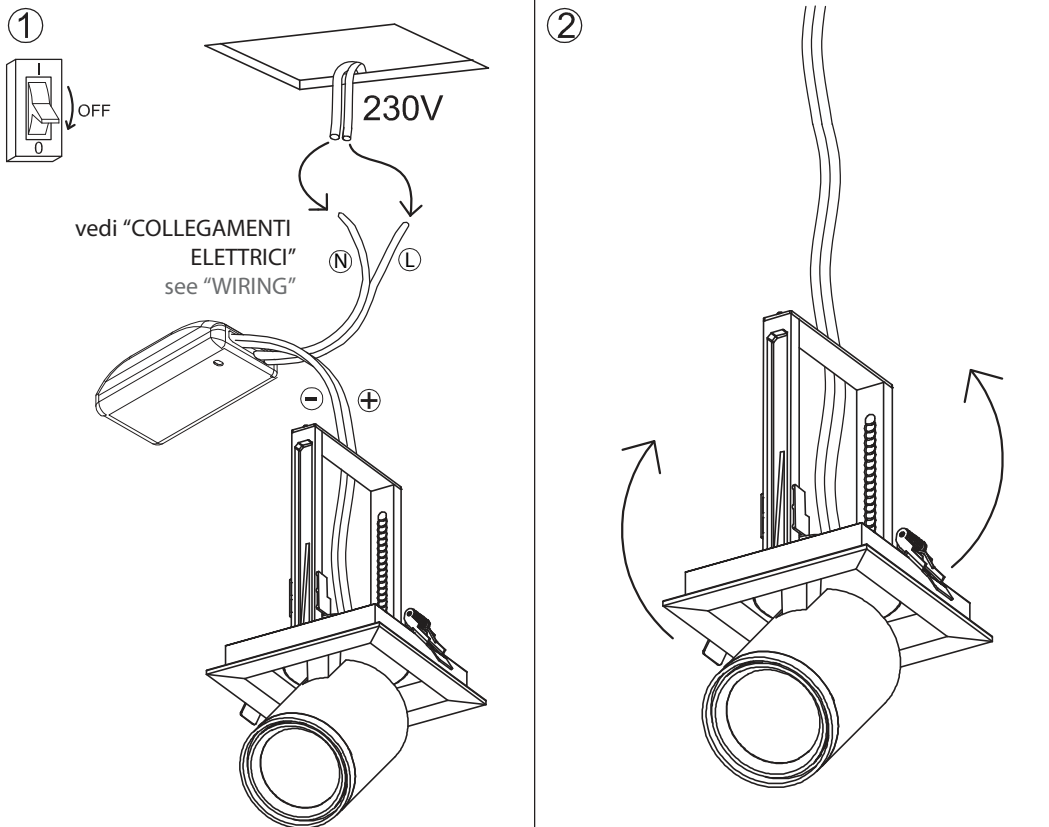

135x135mm cod. 5656

145x145mm cod. 5657

160x160mm cod. 5658

ON-OFF

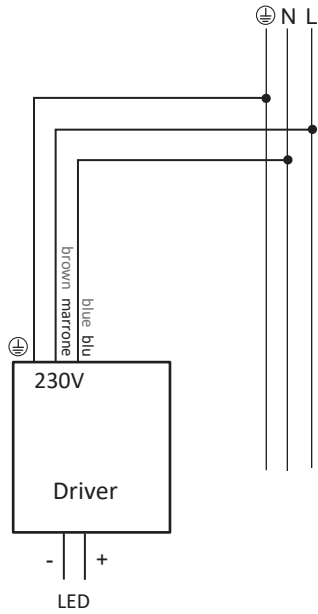

ON-OFF + EMERGENZA (cod. .../EM)

I neutri possono essere messi in comune.
Neutrals can be pooled.

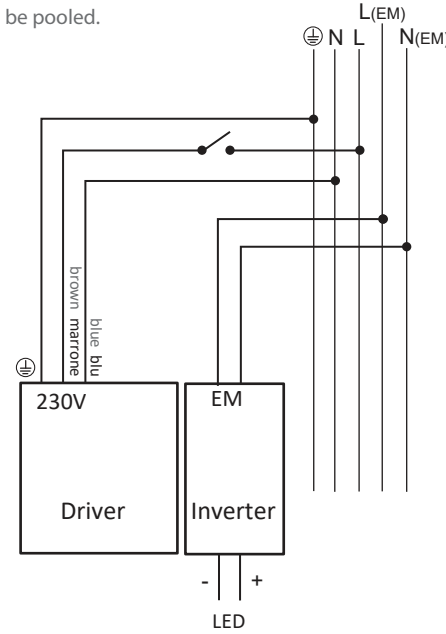

DALI (cod. .../D2)

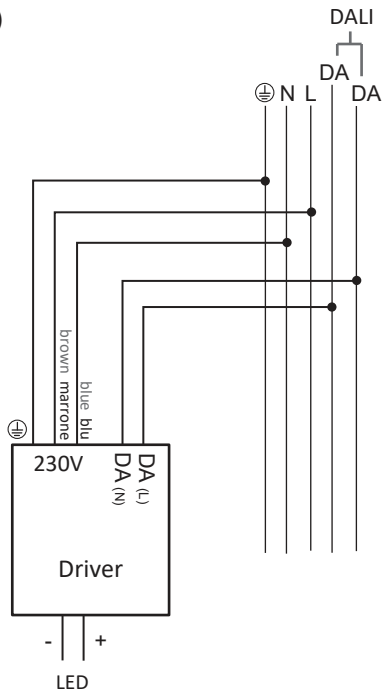

SWITCH-DIM (cod. .../D3)

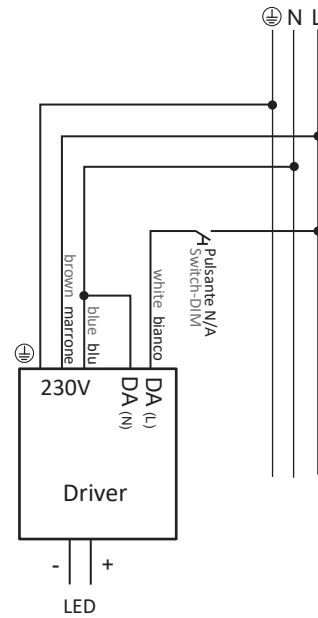

TAGLIO DI FASE (cod. .../DTF) PHASE CUT DIMMER

